

EVERET™

Garage Equipment Solutions

2017

A brand owned by EAE group

EAE Automotive Equipment Company Limited

EAE Wujiang

1089 North Yunlian Rd.Wujiang
Suzhou Jiangsu
Tel 0086-512-63032886

EAE Shanghai

Rm 501, Bldg 2, No.600, West Yunling
Rd.Putuo, Shanghai
Tel/Fax 0086-21-32500750/32500785

EAE UK

Unit 3D,Vanguard Way
Shrewsbury Shropshire SY1 3TG
Tel 44 0173 211264/44 8448007522

ABOUT US



Since 2003, we, EAE Automotive Equipment Company Limited, with manufacturing facility in Wujiang and over 300 employees, focusing on passenger and commercial vehicle service lifts, have been one of the forefront garage equipment exporters in China.



In recent years, we have taken great stride in market expansion both overseas and in China. With a complete portfolio of passenger vehicle lifts under 8000KG load capacity that are manufactured in-house at our Wujiang manufacturing facility, our products and solutions have been commissioned in over 90 countries. In addition, we have been exceptionally successful in domestic passenger vehicle lift market, winning numerous awards, projects, approvals, and certifications from a number of world-renowned car manufacturers.



However, because of our realizing that the market is ever changing and competition increasing, we never ignore our heavy focus in research and development, and product FMEA/longevity testing, product training, and demonstration of our products and solutions.



EVERET, a brand owned by EAE group, aims to provide a comprehensive garage equipment solutions. With the professional team in sourcing, supply chain management, quality control etc, EVERET is your ideal choice for one stop buying.

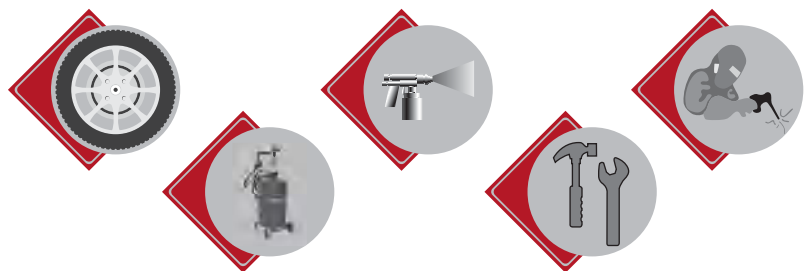

CONTENT



TIRE SERVICE SERIES

TIRE CHANGER	2-10
WHEEL BALANCER	11-12
WHEEL ALIGNER	13-16
NITROGEN TIRE INFLATOR	17
TIRE VULCANIZING MACHINE	18
TIRE SPREADER	19



AUTO PAINTING SERIES

SPRAY BOOTH	21-28
PREPARATION ROOM	29-31
GROUND MOBILE DUSTEXTRACTION STATION	32-33
PAINTING MIXING ROOM	34
INFRARED HEATER	35



AUTO BODY REPAIR SERIES

AUTO COLLISION REPAIR EQUIPMENT	37
WELDING MACHINGE & SPOT WELDING MACHINE	38

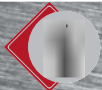

SHOP EQUIPMENTS

PNEUMATIC OIL COLLECTING & DRAINING MACHINE	40
BRAKE TESTER	41-42
SCREW COMPRESSOR	43
AIR COMPRESSOR	44
BRAKE LATHE	45
TOOL TROLLEY	46
PARTS WASHER & SAND BLASTER	47
OIL METER GUN	48
WALL MOUNTED OIL DISPENSING PUMP	49
OIL DISPENSING TROLLEY KITS	50
HOSE REEL	51-52
AC REFRIGERANT RECOVER MACHINE	53
AUTOMATIC TRANSMISSION	54
BRAKE OIL	55
POWER STEERING MCHINE	56
AIR OPERATED GREASE PUMP	57



SHOP TOOLS SERIES

HYDRAULIC TOOLS	59-63
HYDRAULIC VEHICLE POSITIONING JACK	64

TIRE SERVICE SERIES

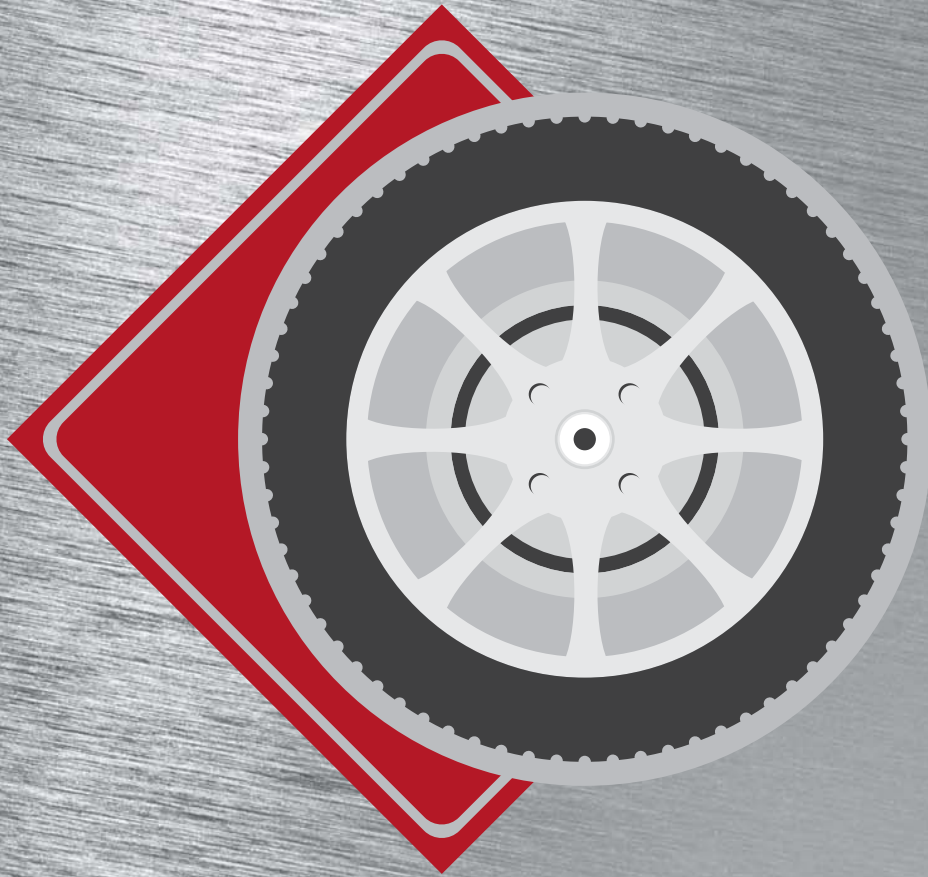

EE-4601



EE-4900A



EE-4430



EE-4404



EE-4408



522-C



EE-3096



EE-3096A



EE-3099



EE-3448



EE-MA



EE-WA800



EE-NI35P



EE-NI60P



EE-NI70P



TIRE CHANGER

MAIN FEATURES

- Leverless head makes tire mounting and demounting easy and quick, prevents damage to tire and rim.
- The dual speed motor (380v) allows operator to change the turning speed easily.
- The pneumatic locking system of assist arm is easy to use.
- The control handle and foot pedal make the operation easier and faster.
- Powerful bead auxiliary arm makes the tire assemble/disassemble fast and efficient.
- Humanization design of the lever makes operating head align the rim accurately.
- Dual layers mainframe design reduce the resonance and noise effectively.
- \varnothing 200mm aluminum air cylinder.
- Optional: air blast device.

522-C

Lever Less
Dual Speed
Standard Assistant Arm



DETAIL DISPLAY



New type of leverless tool head



Mechanical pressing device convenient for falling down the vertical shaft



Optional manual control bead breaker makes easier to operate



Dual-speed motor for 380V make tire mount/demount more efficiently

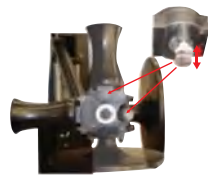

One more pressing point and plastic disk with quick changeable device

TECHNICAL DATA

Models	Internal clamp	Max. wheel diameter	Max. wheel width	Power supply	Motor power	Air supply	Noise level
522-C	14~26"	41"(1050mm)	13"(330mm)	220/380,1/3PH	1.1/0.7-0.9kw	8-10Bar	<70db

TIRE CHANGER

For Car And Motorcycle Tire EE-4601



MAIN FEATURES

- Car and motorcycle tire changer.
- Semi-automatic side swing arm.
- With self-centering function.
- Adjustable mount/demount head.
- \varnothing 80 air cylinder, chromium-coated piston rod reduce the friction effectively.
- CE certificated.

MAIN FEATURES

- Tire changer for low profile tire.
- Semi-automatic side swing arm.
- Durable mainframe for long service life.
- With self-centering function.
- Adjustable mount/demount head.
- \varnothing 80 air cylinder, chromium-coated piston rod reduces the friction effectively.
- Bead breaker for car and motorcycle.
- Mounting head angle is made to be adjustable to suit for rim with different size.
- CE certificated.
- Optional round column serves as air blast reservoir.

EE-4900A



Round Column

MAIN FEATURES

- Especially used for run-flat tires (RSC) and flat tires.
- Automatic tilt back tire changer.
- Pedal assembly may draw from front cover.
- Tilting back column and pneumatic locking system.
- With self-centering function.
- Adjustable mount/demount head.
- \varnothing 80 air cylinder, chromium-coated piston rod reduces the friction effectively.
- Aluminum-alloy valve bodies with durable corrosion resistant stainless steel valve rod.
- CE certificated.

EE-4430



Automatic Tilt Back Column

TIRE CHANGER

EE-4112d Basic Model



MAIN FEATURES

- Semi-automatic side swing arm.
- Durable mainframe for long service life.
- With self-centering function.
- Adjustable mount/demount head.
- \varnothing 80 air cylinder, chromium-coated piston rod reduces the friction effectively.
- CE certificated.

TIRE CHANGER

TIRE CHANGER







SPECIFICATIONS

Models	EE-4601	EE-4112d	EE-4900A	EE-4430
Rim material	Steel, Al., Alloy	Steel, Al., Alloy	Steel, Al., Alloy	Steel, Al., Alloy
Max. wheel diameter	38"	38"	38"	41"
Max. wheel width	10"	12"	15"	15"
Inter clamp	11"-22"	12"-22"	14"-26"	14"-26"
Outer clamp	9"-20"	10"-20"	12"-24"	12"-24"
Motorcycle clamp	/	9"-22"	9"-24"	9"-24"
Power supply	110V/220V/380V	10V/220V/380V	110V/220V/380V	110V/220V/380V
Motor power	0.75KW/1.1KW	0.75KW/1.1KW	0.75KW/1.1KW	0.75KW/1.1KW
Air supply	8-10Bar	8-10Bar	8-10Bar	8-10Bar
Noise level	<70dB	<70dB	<70dB	<70dB

STANDARD ACCESSORIES

Models	Plastic Inserts	Motorcycle Mounting Demounting Head	Plastic Bead Breaker Protector	Filter Regulator	Crowbar	Air Inflation Gun	Air Inflation Hose	Soap Reservoir	Turntable
Picture									
EE-4601	Y	Y	Y	Y	Y	Y	Y	Y	Y
EE-4112d	Y	N	Y	Y	Y	Y	Y	Y	Y
EE-4900A	Y	N	Y	Y	Y	Y	Y	Y	Y
EE-4430	Y	N	Y	Y	Y	Y	Y	Y	Y

OPTIONAL ACCESSORIES

Models	Motorcycle adapter	Plastic Mounting Demounting Head	Air Tank	Bead Blaster	Assistant Arm	Assistant Arm	Assistant Arm
Picture							
EE-4601	N	Y	Y	N	N	N	N
EE-4112d	Y	Y	Y	N	N	N	N
EE-4900A	Y	Y	Y	N	N	N	Y
EE-4430	Y	Y	N	Y	Y	Y	N

TIRE CHANGER

EE-4896



MAIN FEATURES

- The bead break power is up to 1400kg.
- The automatic demounting hook device without the crowbar, which saves time and labor.
- The lifting device with lifting power 80kg can assist people to turn the tire.
- The helper arm has angle forwarding function, which is easier to separate the tire from rim.
- Suitable for low-profile and explosion –proof tire.

TECHNICAL DATA

	EE-4896
Rim material	Steel, Al., Alloy
Max. wheel diameter	1200mm
Max. wheel width	3- 14"
Rim diameter	13"-30"
Power supply	380V
Rpm	6.5/13rpm
Motor power	0.8-1.2KW
Pressing Force	1400kg
Air supply	8-10Bar
Max lifting weight	80kg
Noise level	<70dB

DETAILS DISPLAY



Lift



Quick nut thread shaft



Leverless tool head



Support



Filter Regulator



Console

TRUCK TIRE CHANGER

For 14"-26" Light Track Tires
Semi-automatic

EE-4404



MAIN FEATURES

- Power pump runs only when the tire changer is in use for more efficient operation and reduction of associated costs
- Self-centering, standard clamping capacity of 14 to 26 inches. Chuck rotation operates clockwise and counter-clockwise.
- Adjustable mount and demount head can accommodate different wheel sizes.
- Tool head includes standard disk and hook for bead loosening, mounting and demounting tires. The hook tool folds out of the way when not in use.
- Portable control system is convenient for operator to observe from different angle, improving the efficiency and safety.
- Operation voltage 24V.
- Emergency control switch.

OPTIONAL ACCESSORIES



Alu-alloy Rims Protection Set



Tubeless Roller



Alu-alloy Rims Protection RINGS

TECHNICAL DATA

Models	EE-4404
Rim Clamping Capacity	14"-26"
Max.wheel weight	500kg
Max. Wheel Assembly Width	780mm
Max. Wheel Assembly Diameter	1600mm
Pump Motor	1.5 kw,380v-3ph,50Hz(220V Optional)
Gearbox Motor	1.8kw, 380v-3ph 50Hz(220V Optional)
Bead breaker force	2500kg
Operation control voltage	24V
Power	220V/400V/50/60HZ/1P/3P Optional

TRUCK TIRE CHANGER

For 14"-42"
Heavy Truck Tires
Automatic

EE-4405



MAIN FEATURES

- Power pump runs only when the tire changer is in use for more efficient operation and reduction of associated costs
- Self-centering, standard clamping capacity of 14 to 42 inches. Chuck rotation operates clockwise and counter-clockwise
- Adjustable mount and demount head can accommodate different wheel sizes.
- Tool head includes standard disk and hook for bead loosening, mounting and demounting tires. The hook tool folds out of the way when not in use.
- Portable control system is convenient for operator to observe from different angle, improving the efficiency and safety.
- Operation voltage 24V
- Emergency control switch

OPTIONAL ACCESSORIES



Alu-alloy Rims Protection Set



Tubeless Roller



Alu-alloy Rims Protection RINGS

TECHNICAL DATA

Models	EE-4405
Rim Clamping Capacity	14"-42"
Max.wheel weight	1600kg
Max. Wheel Assembly Width	1050mm
Max. Wheel Assembly Diameter	2300mm
Pump Motor	2.2 kw,380v-3ph,50Hz
Gearbox Motor	2.2kw, 380v-3ph 50Hz
Bead breaker force	3300kg
Operation control voltage	24V
Power	220V/400V/50/60HZ/1P/3P Optional

TRUCK TIRE CHANGER

For 14"-56"
Heavy Truck Tires
Automatic

EE-4408

MAIN FEATURES

- Efficient electro-hydraulic-powered tire changer that combines a range of unique features and capabilities to make wheel service for trucks, buses, tractors and other specialized machinery faster, easier and more profitable.
- Self-centering, standard clamping capacity of 14 to 56 inches. Two-speed chuck rotation operates clockwise and counter-clockwise.
- Adjustable mount and demount head can accommodate different wheel size.
- Tool head includes standard disk and hook for bead loosening, mounting and demounting tires. The hook tool folds out of the way when not in use.
- Portable control system is convenient for operator to observe from different angle, improving the efficiency and safety.
- Operation voltage 24V.
- Emergency control switch.



OPTIONAL ACCESSORIES



Alu-alloy rims protection rings

TECHNICAL DATA

Models	EE-4408
Rim Clamping Capacity	14"-56"
Max.wheel weight	2000kg
Max. Wheel Assembly Width	1200mm
Max. Wheel Assembly Diameter	2500mm
Pump Motor	2.4/3.0kw
Gearbox Motor	2.4/3.0kw
Power	400V 3PH 50HZ

STANDARD ACCESSORIES



WHEEL BALANCER

**Manual
Data Input (A/D)
EE-3096v2**



**Automatic
Data Input (A/D)
EE-3096Av2**



**LED Screen
Automatic
Data Input (A/D)
EE-3500**



MAIN FEATURES

EE-3096v2

- Input distance rim/machine and rim diameter and width via keys.
- DYN mode for standard rim, 4 ALU modes for alloy rims or special shaped rim, statistic mode for motorcycle rim, and OPT mode for optimization.
- Pluggable position pick up board.
- Self diagnoses, easy to find the problem.
- Optional Pedal-operated main shaft lock.
- Optional motorcycle adaptor.
- CE certified by TUV.
- EMC certified.

EE-3096Av2

- Automatic input of distance rim/machine and rim diameter.
- Input width via keys.
- DYN mode for standard rim, 3 ALU modes for alloy rims or special shaped rim, statistic mode for motorcycle rim, and OPT mode for optimization.
- Pluggable position pick up board .
- SP and hidden weight mode.
- Self diagnoses, easy to find the problem.
- Optional Pedal-operated main shaft lock.
- Optional motorcycle adaptor.
- CE certified by TUV.
- EMC certified.

EE-3500

- with LED display for car and light-truck wheels.
- Automatic input of distance rim/machine and rim diameter.
- DYN mode for standard rim, 6 ALU modes for alloy rims or special shaped rim, statistic mode for motorcycle rim, and OPT mode for optimization.
- Aluminium gauge head with wheel weight clamp.
- SP and hidden weight mode.
- Pedal-operated main shaft lock.
- Self diagnoses, easy to find the problem.
- Optional motorcycle adaptor.
- CE certified by TUV.
- EMC certified.

TECHNICAL DATA

Models	EE-3096v2	EE-3096Av2	EE-3500
Rim diameter	10"-24"	10"-24"	10"-24"
Rim width	1.5"-20"	1.5"-20"	1.5"-20"
Rotating speed	200R.P.M	200R.P.M	200R.P.M
Balancing precision	1g	1g	1g
Max.Wheel weight	65Kg	65Kg	65Kg
Max.Wheel diameter	1000mm	1000mm	1000mm
Noise level	<70db	<70db	<70db
Motor power	0.2Kw	0.2Kw	0.2Kw
Power supply	110/220V,1PH	110/220V,1PH	110/220V,1PH

STANDARD ACCESSORIES



OPTIONAL ACCESSORIES

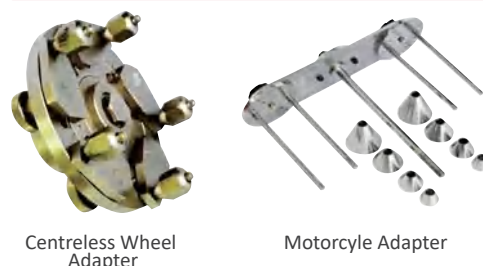

TRUCK WHEEL BALANCER

EE-3448



MAIN FEATURES

- Suitable for wheels of heavy truck and bus.
- Pneumatic wheel lifting device.
- Various balancing modes.
- Pedal-operated main shaft lock.
- Steel supported bottom to make the cabinet stable.
- CE certified by TUV.

TECHNICAL DATA

Models	EE-3448
Max.Wheel weight	150Kg
Max.Tire diameter	1200mm
Rim diameter	13"-24"
Rim width	5.5"-20"
Balancing speed	200R.P.M
For truck tire	50Kg
Power supply	380V/50/3PH
Motor power	0.5Kw
Working pressure	6-8bar
Noise level	70db
Package Size	1750x900x1280mm
N.W.	250Kg
G.W.	400Kg

STANDARD ACCESSORIES



Caliper



Weight



Cone



Wheel Hood



Quick Nut



Flange



Weight Plier

3D WHEEL ALIGNER

EE-WA900



MAIN FEATURES

- Mini Targets
- Electronically adjustable post
- Wheeled cabinet
- 19" LCD monitor
- Minor space request, super short setup distance
- Comprehensive database coverage

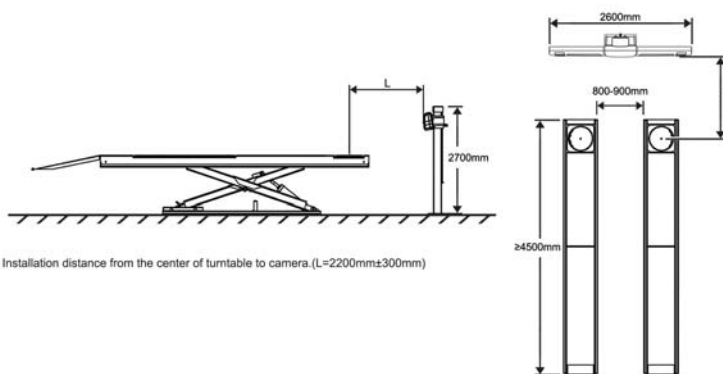

TECHNICAL DATA

EE-WA900	Accuracy	Range
Total toe(front and rear)	±4'	±50°
Single toe(left and right)	±2'	±25°
Camber(front and rear)	±1'	±15°
Set back	±4'	±9°
Thrust angle	±2'	±9°
Caster	±4'	±22°
SAI(KPI)	±4'	±22°
Track width	±1mm	1.2-2.1m
Wheel base	±1mm	1.8-4.5m

OPTIONAL ACCESSORIES



Calibration kit for imaging aligner



Aluminum alloy turn table

3D WHEEL ALIGNER

EE-WA990



MAIN FEATURES

- Black diamond mini targets(BDM)
- Lift system with Self-locking mechanism
- VIN scan
- Automatic synchronized camera and target movement
- 32"LCD monitor
- Minor space request, super short setup distance
- Comprehensive database coverage
- Multi-bay compatible

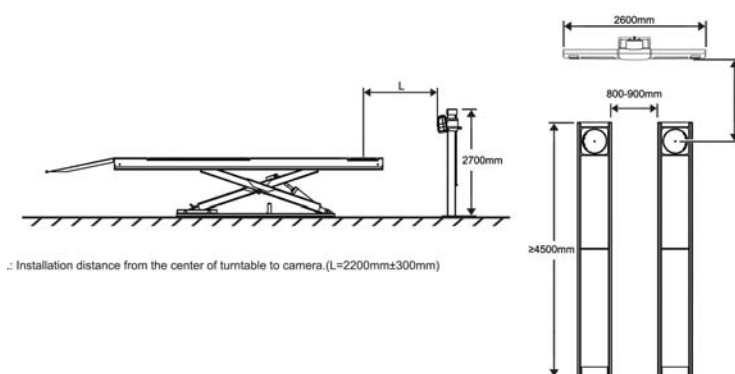

TECHNICAL DATA

EE-WA990	Accuracy	Range
Total toe(front and rear)	±4′	±50°
Single toe(left and right)	±2′	±25°
Camber(front and rear)	±1′	±15°
Set back	±4′	±9°
Thrust angle	±2′	±9°
Caster	±4′	±22°
SAI(KPI)	±4′	±22°
Track width	±1mm	1.2-2.1m
Wheel base	±1mm	1.8-4.5m
wheel diameter	±1mm	250-800m

OPTIONAL ACCESSORIES



Calibration kit for imaging aligner



Aluminum alloy turn table

CCD WHEEL ALIGNER



EE-WA800

MAIN FEATURES

- 3600 line CCD aligner and 8 beam infrared optical sensors.
- ZIGBEE wireless technology for 4 sensors communication.
- The sensors are effective shield against the strong light with special filter system.
- The software can automatically detect problems of sensor.
- Inclinator with temperature compensation.
- The maximum of axle distance can reach 8 meters.
- The sensor with LiFePO4 can run no-stop for 24 hours with the 2900mA battery.
- Software language: French, English, German, Russian, Spanish, Korean.
- Linux, Vista or Windows 7, Windows 8, Windows XP OS supported.

TECHNICAL DATA

Models	EE-WA800	
Measuring parameter	EE-440 Measuring accuracy	Measuring range
Toe angle	$\pm 0.03^\circ$	$\pm 20^\circ$
Single toe angle	$\pm 0.01^\circ$	$\pm 10^\circ$
Camber angle	$\pm 0.02^\circ$	$\pm 15^\circ$
Trust angle set back	$\pm 0.02^\circ$	$\pm 9^\circ$
Kingpin caster angle	$\pm 0.05^\circ$	$\pm 20^\circ$
Kingpin inclination angle	$\pm 0.05^\circ$	$\pm 20^\circ$
Steering angle	$\pm 0.10^\circ$	$\pm 24^\circ$

STANDARD ACCESSORIES



ZIGBEE



MAIN BOARD



SENSOR

LASER WHEEL ALIGNER

EE-MA



MAIN FEATURES

- Wheel rims- 12 inches to 23 inches
- Easy mount clamps and alloy friendly clamp contact
- The four laser heads automatically recharge in docking station when not in use.
- Continual operation up to 16 hours
- Drop kit for low spoiler vehicles
- Brake Pedal depressor and Steering wheel clamp included

TECHNICAL DATA

Models	EE-MA
Total Toe Out	20mm
Toe In	30mm
Individual Toe	10mm
Set Back Up to	60mm
Vehicle Measurement Ranges	
Rim Diameter	12"-23"
Maximum Tire Diameter	35" (890mm)
Wheelbase	1000mm-4500mm
Track Width	1000mm-3000mm
Power Supply	
Voltage	110-230V 50/60Hz
Re-Chargeable Battery Packs	LiFePO4 3.4V 1100mAH
Battery Type 1100mAH	1500 cycle min.
Re-Charger Life	0°C-40°C
Storage	
Usage	16 hours capacity, continuous use
Docking Station	
Voltage	5 VDC Maximum
635nm 1mw maximum output	Class 2

STANDARD ACCESSORIES



Angle scale



Touching pole to wheels

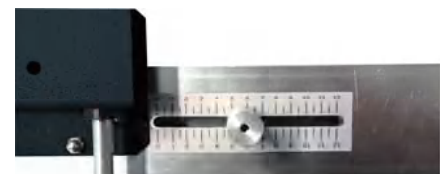

Touching pole to wheels-1



Hanging rack



Target board for back wheels



Measuring pole for front wheel

NITROGEN TIRE INFLATOR

For One Tire



EE-NI135P

For Four Tires



EE-NI160P

For Six Tires



EE-NI170P

MAIN FEATURES

EE-NI135P

- One touch Nitrogen transfer.
- Auto-inflation
- Fully automated, fully programmable, micro-processor controlled conversion system
- Nitrogen purge and fill cycle (N2P)
- Adjustable over pressure setting (OPS)
- Acousto-optic alarm
- Self-diagnostic features
- Backlight LCD display
- Suits for: Motorcycle, Car, Light Truck

EE-NI160P

- One button four tires nitrogen inflation . Converts up to 4 tires to Nitrogen simultaneously at the touch of a button, saving 30% time than single tire inflation
- Fully automated, fully programmable, micro-processor controlled conversion system Nitrogen purge and fill cycle (N2P)
- Adjustable over pressure setting (OPS)
- Acousto optic alarm
- Self-diagnostic features
- Backlight LCD display
- Auto Shut-Off -With castor -Suits for: Car, Light Truck

EE-NI170P

- 145PSI/10bar high pressure nitrogen fits for all type of tires
- One button for six tires nitrogen inflation
- Fully automated, fully programmable, micro-processor controlled conversion system
- Nitrogen purge and fill cycle (N2P)
- Adjustable over pressure setting (OPS)
- Acousto optic alarm
- Self-diagnostic features
- Backlight LCD display
- Auto Shut-Off - With castor
- Suits for: Car, Light Truck, Bus

TECHNICAL DATA

Models	EE-NI135P	EE-NI160P	EE-NI170P
Power Supply	100-240V/50-60HZ	100-240V/50-60HZ	100-240V/50-60HZ
Power Consumption	35VA	35VA	70VA
Working Temperature	-20 °C /70 °C	-20 °C /70 °C	145-217PSI/10-15bar/1000-1500kPa
Compressed Air Input	87-123PSI/6-8.5BAR/600-850KPa	87-123PSI/6-8.5BAR/600-850KPa	95-99+%
Nitrogen Purity	95-99+%	95-99+%	95-99+%
Nitrogen Output	58L/min(2.0cfm)	93L/min(3.3cfm)	228L/min(6cfm)
Maximum Nitrogen Pressure In Tank	102PSI/7bar/700KPa	102PSI/7bar/700KPa	145-174PSI/10-12bar/1000-1200KPa Adjustable
Inflator Accuracy	/	+1PSI/0.07bar/7KPa	+1PSI
Tank Capacity	50L	50L	118L
Display	LCD	LCD	LCD
Keyboard	Mental	Mental	Mental
OPS	Yes	Yes	Yes
N2P	Yes	Yes	Yes

TIRE VULCANIZING MACHINE



EE-TV018
Adjustable

EE-TV088
Auto-controlled



EE-TV520
Adjustable

TECHNICAL DATA

Models	EE-TV018	EE-TV088	EE-TV520
Input voltage	220V	220V	220V
Input power	0.8KW	0.8KW	1KW
Vulcanizing temperature	adjustable	auto-controlled	adjustable
Applicable range	vulcanization of small damage of tube and cover tires of small size	7.50 to 10.00-20 tires.	tires below 9.00
Package(LxWxH)	600x300x750mm	570x290x1100mm	930x370x1340mm
G.W.	22Kg	36Kg	70Kg

TIRE SPREADER



Pneumatic

EE-TE52B

MAIN FEATURES

Working Type:Pneumatic

Applicable Scope:below 12.00 tire

Working Pressure:0.8-1.0MPa.

- According to the tire size, fix the hook into the proper mounting hole.
- According to the tire size, adjust the hook support height.
- The tool shelf makes tools within reach for convenient picking-up and putting-back
- The illumination can also be adjusted according to the working place.
- The water and oil separator can make lubrication function.
- With keeping certain oil level in the oil cup, water moisture in the air can not go inside the air cylinder.

EE-TE02

MAIN FEATURES

Working type:Manual

Applicable scope:Small tire

- The hook can be adjusted according to the tire width for medium-sized and small tire.
- The operating platform can be turned to any place with ideal light during tire repairing.
- Easy for inspecting and repairing tire.



Manual



Pneumatic

EE-TE60

MAIN FEATURES

Working Type:Pneumatic

Applicable Scope:For tire width below 1,200-20 large and medium-sized tire

Working Pressure:1.0-1.2MPa

- The hook can be fixed at three different levels and be adjusted to fit the tire.
- The floor type enables the operator to adjust the operating platform height accordingly.
- The auxiliary tire-loading device can help load the oversized tire with reduced manpower costs and improved efficiency.
- Easily to operating heavy tire.

AUTO PAINTING SERIES

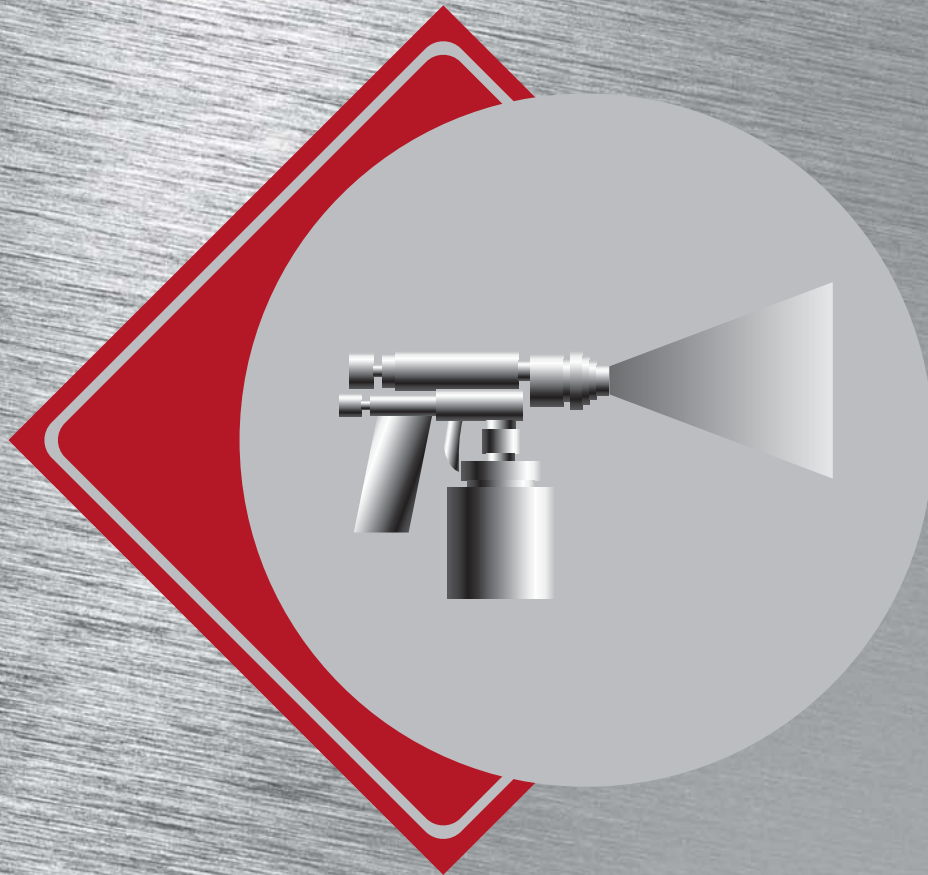

EE-7500



EE-7501



EE-7503



EE-7203CE



EE-7505



EE-7202



EE-7303



SPRAY BOOTH

STRUCTURE

Cabin

Wall panel: sandwich style, polystyrene or rock wool type, two vertical sides covered by galvanized metal sheets, tongue and groove connected with each other; The density of polystyrene is 12kg/m³, and optional rock wool is 105kg/m³. 50mm,60mm,75mm and 100mm thickness are all available as required.

Front door: all the doors are without side cover design, with reinforcement inside for higher load ratings, bigger glass size for better light transmittance. Without rubber around the glass.

Emergency door: side door, works as emergency door, equipped with mechanical pressure lock and automatic return position device, when the pressure differences between outside and inside the cabin reach 100Pa, The door will open automatically.

Basement: Basement is made of galvanized steel and easy to assemble. 2 rows of grids are welded by 30×4 flat steel and 6×6 square steel. 3 rows of vein plates. 2 pcs of vein plate ramps, width 630mm, length 2000mm, good bearing, antiseptic.



Front Door



Wall Panel side with metal covered



Basement



Safety Door Lock

Intake And Exhaust

Fan: centrifugal fan, big vane, vane and motor separated. Centrifugal fan produces great air flow, easy clean, compliant to CE standard. European style professional intake fan, with M-style prefilter. The cabinet for intake fan is with profile steel frame and galvanized plates. Spraying-baking transform by pneumatic damper. Intake and exhaust ducts are separated working.

Air duct: European flange style. Exhaust ducts are standard specification. Intake ducts are for option. With 4m straight ducts and 1 piece elbow.

Damper: spraying-baking function is switched by pneumatic damper, which is controlled by control panel automatically.



Damper Operator



Centrifugal Fan

Cleaning system

pre-filter: prefilter is at inlet, filtering dust above 15um. movable maintenance door to change the filter easier.

Roof filter: multi-layers, filtering dust above 5um, mounted in the bottom of roof air chamber, good seal, fixed by support frame. Small air resistance, long use cycle. Medium air filtration, level F5, filtering 1um-5um, up to 98% filtration rate. 6 pcs of filter frames.

Filter frame: four sides of filter are fitted in the support channel, assuring good sealing. It's easily assembled by hinges and fixed by one worker only.



Filter Frame



Filter



Pre-filter

SPRAY BOOTH

Heating

Burner:Riello G20 diesel burner. Firstly the burner will generate high pressure spark via pulse, then ignite diesel.Reliable and completely burnt. Gas burner or infrared heater for optional .Diesel tank,diesel display tube,and diesel filter collocated.

Heat exchanger:made of stainless steel,large exchange area with high efficiency.



Burner



Heat Exchanger

Illumination System

Illumination system:lighting boxes are installed at both sides of booth in 45° direction. Lamp trays,tubes and power are different according to different models.700-1000lux lighting.



Illumination System

Control Panel

Control panel:high quality components,overload,overheat,phase-lacking protection.with Heat sensor device.The whole operation with stop automatically when the heating system reach the preset time and temperature. With constant temperature spraying function.



Automatic Control Box



Thermometer



Timer

Water-based paint system

Optional water-based paint system:nozzles installed on both sides in top 45 degrees direction, or at each corner. Adopt independent fan system to speed up heated air circulation,shorten curing time of oil slick.



Water Painting Compliant

Environmental Protection System

Optional environmental protection system:layers style,absorbing the toxic substance, reducing the harmful gas emissions



Environmental Protection Device

SPRAY BOOTH

SPRAY BOOTH

For Bus
EE-7303



New Model
EE-7505



Simple
EE-7500



For Minibus
EE-7202



Basic
EE-7503



CE
EE-7203CE



Basic
EE-7501



SPRAY BOOTH

SPRAY BOOTH

TECHNICAL DATA

Models	EE-7500	EE-7501	EE-7503	EE-7203CE	EE-7505	EE-7202	EE-7303
Overall size,m (L*W*H)	8.1 x 4.0 x 3.2	7.0x5.3x3.5	7.0x5.3x3.5	7.0x5.3x3.5	7.0x5.56x3.45	8.7x5.63x4.23	15.2x6.7x5.0
Inner size,m (L*W*H)	6.9 x 3.9 x 2.7	6.9x3.9x2.7	6.9x3.9x2.7	6.9x3.9x2.7	6.9x4.0x2.65	8.6x4.0x3.4	15.0x5.0x4.4
Entrance door ,m(W*H)	3*2.66	3x2.66	3x2.66	3x2.66	3x2.6	3x3.35	4x4
Intake Fan capacity(M3/H)	/	24000	24000	24000	24000	35000	72000
Exhaust Fan Capacity(M3/H)	21000	/	21000	24000	24000	24000	72000
Wall panel thickness(mm)	50	50	50	50	50	50	75
Wall panel Steel thickness (mm)	0.326	0.326	0.326	0.426	0.426	0.426	0.426
Air velocity,m/s	0.25-0.35	0.25-0.35	0.25-0.35	0.25-0.35	0.25-0.35	0.25-0.35	0.25-0.35
Air ventilation times	265	265	265	265	265	333	333
Working temperature	/	60-80	60-80	60-80	60-80	60-80	60-80
Oil consumption,kg/pc	/	6-8	6-8	6-8	6-8	9-10	9-10
Ceiling Panel(galvanized steel)	0.6mm	0.6mm	0.6mm	0.8mm	0.8mm	0.8mm	0.8mm
Air in-taker (KW)	/	1x7.5	1x7.5	1x7.5	2x4	1x11	2x11
Air Exhauster(KW)	1*5.5KW	/	1x5.5	1x7.5	1x7.5	1x7.5	2x11
Power,(KW)	7KW	9.5	16	18	17.5	20.5	50
Safe door	1 fold of front door as safe door	1870x650mm	1870x650mm	2000x800mm	2000x800mm	2000x800mm	2000x800mm
Thermal Insulation	Polyethylene	Polyethylene	Polyethylene	rock wool	Polyethylene	rock wool	rock wool
Oil Burner	X	RIELLO,G20	RIELLO,G20	RIELLO,G20	RIELLO,G20	RIELLO,G20S	RIELLO,RG5S*2
Dampter	pneumatic	pneumatic	pneumatic	pneumatic	Electrical (20N actuator)	pneumatic	pneumatic
Control system	Chinese components, Motor direct start	Chinese components, Motor direct start	Imported components, Motor direct start	CE components; Motor Y/△ start	Imported components, Motor direct start	Imported components, Motor Y/△start	Imported components, Motor Y/△ start
Filter system	China Made	Italy Made	Italy Made	Italy Made	Italy Made	Italy Made	Italy Made
Upper corner lights	32pcs	40pcs	40pcs	40pcs	32pcs	48pcs	80pcs
Side light	X	X	16pcs	32pcs	16pcs	/	64pcs
Pressure Meter	optional	optional	optional	•	optional	•	•
Environment system	optional	optional	optional	optional	•	optional	optional
water-soluble painting	optional	optional	optional	optional	optional	optional	optional
Gas burner	optional	optional	optional	optional	optional	optional	optional
infrared light heating	optional	optional	optional	optional	optional	optional	optional

FOUNDATION DRAWING

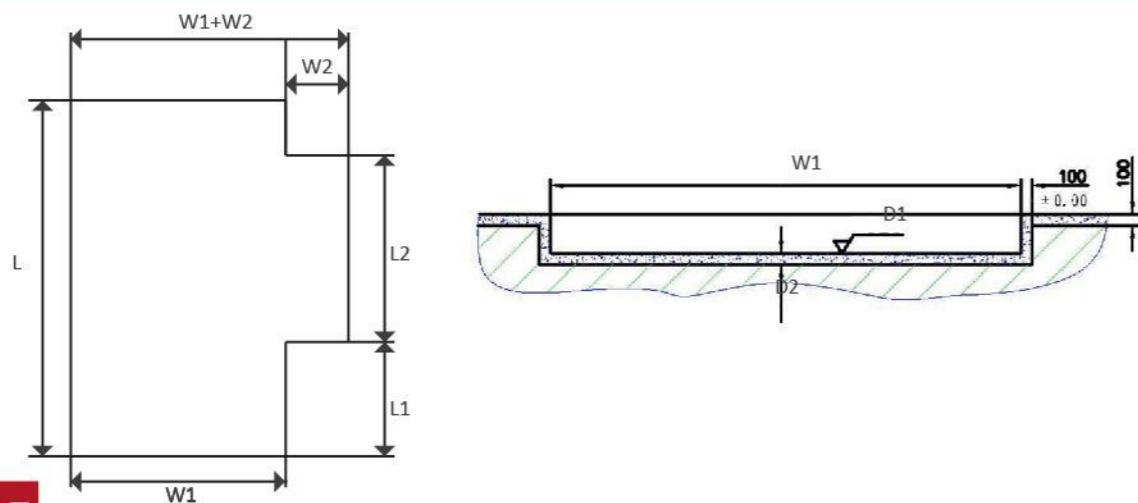

	EE-7501	EE-7503	EE-7500	EE-7505	EE-7203CE	EE-7202	EE-7303
W1(mm)	4200	4200	4000	4200	4200	4300	5150
W2((mm)	1300	1300	1055	1500	1300	1525	1520
W1+W2(mm)	5500	5500	4000	5700	5500	5825	6670
L(mm)	7200	7200	7000	7100	7200	8900	15150
L1(mm)	2300	2300	1055	2100	2300	2300	2450
L2(mm)	3150	3355	1600	2800	3800	4150	4050x2+2150
D1	320	320	/	300	320	320	1100
D2	100	100	/	100	100	100	100-200

SPRAY BOOTH

EE-7505CE



MAIN FEATURES

- With the Germany TUV certification
- Wall panel Steel thickness is 0.426mm, make cabin very rigidity.
- The heating exchanger is made of 1.5-2.0mm SUS304 stainless steel double bile, excellent quality.
- Roof panels are made by 0.8mm galvanized steel plates
- The electronic control box components are Schneider and Siemens brand
- 2X 7.5KW direct drive turbine fan, the motor are Siemens Electronics
- Optional full grids
- Optional side exhaust
- Optional Riello RG55 diesel burner or gas burner.
- Optional water-soluble painting

FOUNDATION DRAWING

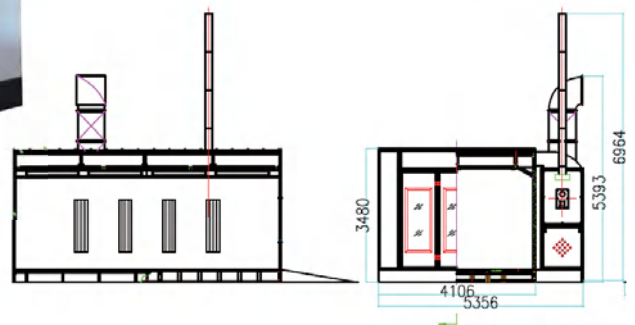

DETAILS DISPLAY



Metal sheet front door
With clear tempered glass



Turbine fan



3 pcs of veins plates style ramps



Pneumatic damper



Heat cabin



Riello G20 Burner



Ceiling Panel 0.8mm thick galvanized steel



Schneider Circuit Breakers
Schneider contactor
Schneider thermal protector

SPRAY BOOTH

DETAILS DISPLAY



Micro computer spraybooth control plate



New style aluminum hing



New door plug



5 twist steel ribs grids

TECHNICAL DATA

Models	EE-7505CE
External size(m)	7.00x5.36x3.48(LxWxH)
Internal size(m)	6.90x4.00x2.65(LxWxH)
Air return style	Full down draft,basement high 300mm
Front door structure	3 folded without frame
Safe door	1 piece in the side wall,2000*800mm
Wall panel material	50mm Rock wool panels
Steel thickness(mm)	0.6MM
Top light	2sides, 4set per side, 4pcs 16W LED lamps per set. Total: 2x4x4=32pcs 16W LED lamps
Side light	2sides, 4sets per side, 2pcs 16W LED lamps per side. Total: 2x4x2=16pcs 16W LED lamps
Electric wire connect	All connect points use amphenol connector
Intake fan(KW)	1set 7.5Kw Siemens motor turbo fan
Exhaust fan(KW)	1set 7.5Kw Siemens motor turbo fan
Total power(KW)	16KW
Generator frame	Iron frame with aluminum angle
Heat exchanger	2.0mm SUS304 stainless steel argon arc welding, double layers heat sinks
Chimney	Chimney is made by stainless steel.
Damper	Pneumatic damper
Buner	Italian Riello G20
Exhaust duct	Air inlet duct: 4M straight ducts,1pcs rain-proof hood with bird-proof mesh. Air exhaust duct: 4M straight ducts,1pcs flop damper.
Control Box	Imported components, Motor star delta start, overload, overheat, phase-lacking
filter	imported
filter installed	hingle installed, mounted above support frame
Floor	3 rows of veins plate, 2 rows of 5 twist steel ribs grids. Galvanized grilles.
Ramp	3 pcs of veins plates style ramps
Enviromental system	Fiber glass filter mesh and active carbon filter bags.
Fan capacity(M3/H)	25,000
Air velocity(m/s)	0.25-0.35
Max drying temperature	60 C -80 C
Motor Voltage	380V/50HZ/3PH(If you need other power supply, we will add some cost for each blower)

PREPARATION ROOM

EE-7660



EE-7640



EE-7650



MAIN FEATURES

EE-7660

- Down draft, air intaked from roof and exhausted through basement
- With basement, ceiling, lighting and curtain
- Filter support net and lights in the ceiling, simple paint working can be operated.

EE-7650

- Down draft, air intaked from roof and exhausted through basement
- With 2 rows of grids, ceiling, lighting and curtain
- Filter support net and lights in the ceiling, simple paint working can be operated.

EE-7640

- Without basement, with ceiling, lighting and curtain.
- semi-down draft, filtered air exhaust from rear side wall panel
- Filter support net and lights in the ceiling, simple paint working can be operated.

PREPARATION ROOM

Model No.	EE-7660	EE-7650	EE-7640
External Size (Lxwxh)mm	7.1x3.7x3.52	7.1x3.7x3.2	7.1x3.7x3.2
Internal Size (Lxwxh)mm	6x3.48x2.7	6x3.48x2.7	6x3.48x2.7
Back Wall Panel Structure	wall panel only	wall panel only	Filter net structure at bottom back wall , Ventination at through the back wall
Material	EPS, Thickness: 50mm	EPS, Thickness: 50mm	EPS, Thickness: 50mm
Color Steel	Thickness: 0.326mm with metal edge cover	Thickness: 0.326mm with metal edge cover	Thickness: 0.326mm with metal edge cover
Front Curtain	2pcs,with orange color and transparence	2pcs,with orange color and transparence	2pcs,with orange color and transparence
Sides Curtain	4pcs,with orange color and transparence	4pcs,with orange color and transparence	4pcs,with orange color and transparence
Top Light(Pcs)	32	32	32
Side Light	/	/	/
Generator Place	place at the back	place at the back	place at the back
Generator Frame	Iron frame with Aluminum angle,Powdered	Iron frame with Aluminum angle,Powdered	Iron frame with Aluminum angle,Powdered
Fan Capacity	1x5.5kw	1x5.5kw	1x5.5kw
Duct	4 m straight dusts and 1 piece 90°ben.	4 m straight dusts and 1 piece 90°ben.	4 m straight dusts and 1 piece 90°ben.
Vcd Adjust Damper	2 pieces damper controlled by electric . Place at the Air enter and and exhaust duct	2 pieces damper controlled by electric . Place at the Air enter and and exhaust duct	2 pieces damper controlled by electric . Position at the Air enter and and exhaust duct
Fan Capacity	(18000)M3/h	(18000)M3/h	(18000)M3/h
Control Box	Chinese components,motor direct start	Chinese components,motor direct start	Chinese components, motor direct start
Total Power	7 kw	7kw	7kw
Structure	/	Concrete basement,dig two hole by user	concrete floor
Floor	All grids	Two rows grids	/
Floor Filter	Made in China, 5 rows	Made in China, 2 rows	/
Ramps	2 pcs of veins plates style ramps	/	/
Top Filter	Made in China, (4 pcs/set)	Made in China, (4 pcs/set)	Made in China, (4 pcs/set)
Structure	Hinge installed, iron welded, powdered	Hinge installed, iron welded, powdered	Hinge installed, iron welded, powdered
Installation Style	6 post to support the air room.suspend to the ceiling of the workshop for optional)	6 post to support the air room.suspend to the ceiling of the workshop for optional)	6 post to support the air room.suspend to the ceiling of the workshop for optional)
Motor Voltage	380V/50HZ/3PH	380V/50HZ/3PH	380V/50HZ/3PH

FOUNDATION DRAWING

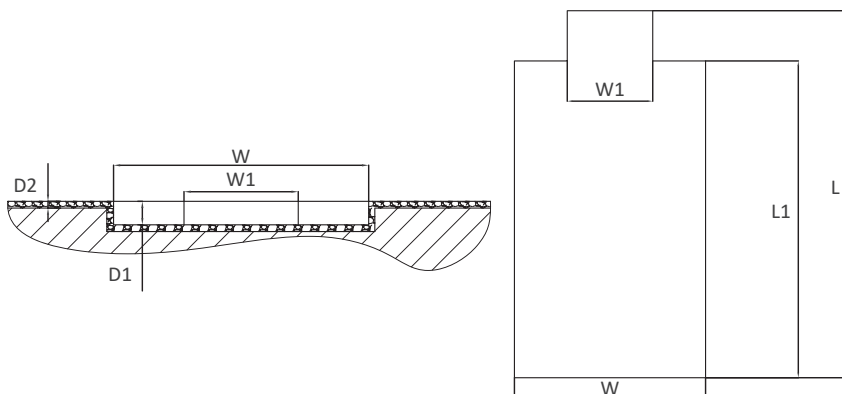

	EE-7660	EE-7650	EE-7640
W(mm)	3800	3800	3800
L1(mm)	6300	6300	6300
L(mm)	7300	7300	7300
W1(mm)	1700	1700	1700
D1(mm)	350	/	/
D2(mm)	100	/	/

PREPARATION STATION

EE-7630M



MAIN FEATURES

- With universal wheel foot. Movable.
- 3 sides have filter structure, and replace filter easily.
- Economic.

FOUNDATION DRAWING

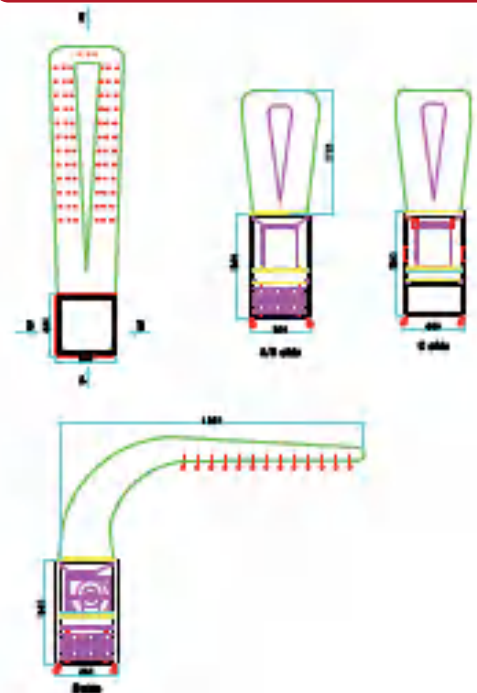

TECHNICAL DATA

Models	EE-7630M
Cabinet size(mm)	880x880x1500mm
Ventilation system	<ol style="list-style-type: none"> 1. Cabinet is made by coated steel structures with coated galvanized steel plate covers. Inner have rock wool protection materials 2. Adopt 1set YDW centrifuge 2.2kW fan. Air capacity: 8210m³/h. Fan bottom assembled 1layer active carbon filtering. 3sides air inlet with premier filters. 3. Roof assembled PVC air blower hood 4. Bottom assembled universal wheels and brake.
Control system	Turning switch style
Voltage	220V, 3Phase, 60Hz
Total power	2.2kW

GROUND MOBILE DUST EXTRACTION STATION

MAIN FEATURES

- Super strong suction force,two people work at the same time bumish
- 5 meters work arm plus 5 meters grinding dust collection tube
- covering two station,high double suction mouth
- Two 220V 15a power socket
- Three gas supply air
- Air pressure monitoring,pressure is adjustable

TECHNICAL DATA

Models	EE-DES100
Power	1.37KW/380V
Filter Area	2.8
Work Pressure:	6KG
Noise	68DB
The Number of Work	2 person

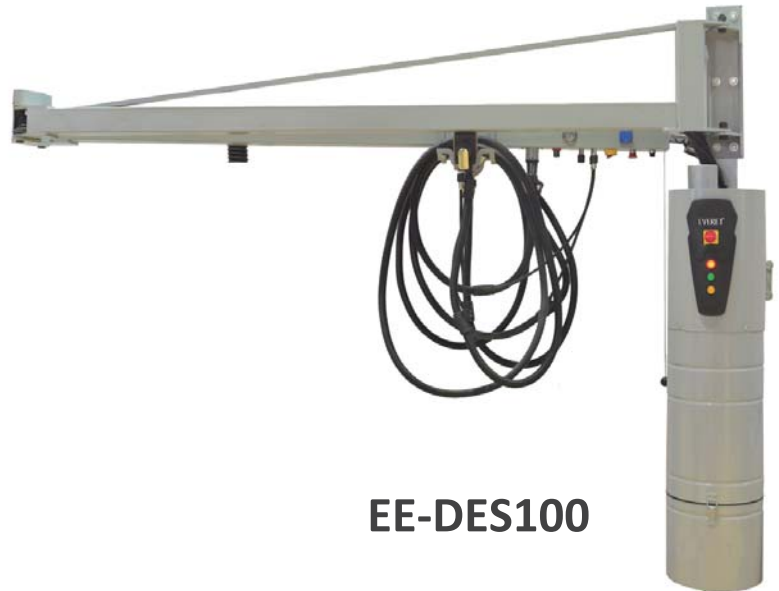

EE-DES100

DETAILS DISPLAY



Automatic star-stop work arm, shutdown can work, automatic dust removal, simple maintenance



Bring the searchlight, use more convenient security



Total power source control dust collection box fault indicator



2.5m+2.5m working arm cover two station, two people can be grinding at the same time



Hanging rack with tools,grinding tools can hang buy to temporarily not work, clean and orderly



With automatic cleaning system of the filter, the filter effect of imported plastic film is better



Square Mill



Coarse Grinding Machine



Fine Grinding Machine



In the Mill



Optimal Industrial Electric No Carbon Brush Grinding Head



Optimal Three Inchesof Grinding Head

GROUND MOBILE DUST EXTRACTION STATION

EE-DES150



MAIN FEATURES

- With the work table can be placed, grinding tools and application materials, in order to work
- Switch can be adjusted, manual, automatic switching
- Comes with the handle, moves the trolley to be more convenient human nature
- The dust collection effect is very strong, and the dust collection effect is more than 90%
- Dust collecting barrel is simple and convenient disassembly
- Grinding tools with grinding rack can hang Write work, clean and orderly
- Run, stop, failure indicator
- Multi direction rotary wheel, easy to move
- Replace the filter is simple and convenient

TECHNICAL DATA

Models	EE-DES100
Power	1.37KW/220V/60HZ
Air flow	210m3/h
Filter Area	2.8m ²
Air pressure	6kg/cm ²

DETAILS DISPLAY



Work table



Grinding tools with grinding rack



Dust collecting barrel



Handle



Replace the filter



Switch



Multi direction rotary wheel



Dust collection



Run, stop, failure indicator



Square Mill



Coarse Grinding Machine



Fine Grinding Machine



In the Mill



Optimal Three Inches of Grinding Head



Optimal Industrial Electric No Carbon Brush Grinding Head

PAINTING MIXING ROOM

EE-7770



STANDARD ACCESSORIES



Equipped with auto-closing door, convenient for getting in and out.

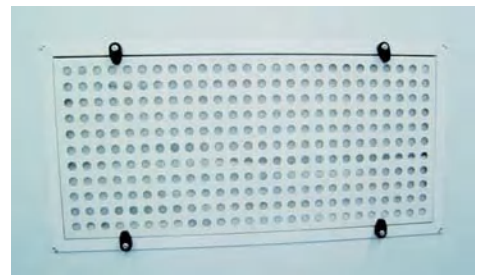

Equipped with filter for intake, supply fresh air continually to improve the air quality.



Equipped with filter for outlet, exhausting the gas in time to keep the workers safe.

MAIN FEATURES

- Painting mixing room is a modern equipment which can improve environment of painting workplace
- It has a reasonable ventilation system which can expel exhaust gas from the booth and supply fresh air inside to improve air quality

TECHNICAL DATA

Models	External Size(m)	Internal Size(m)	Power(Kw)	Remark
EE-7770	2.4x4.0x2.55	2.3x3.9x2.5	0.75	Including centrifugal fan and standard lighting

INFRARED HEATER

Rail-style Infrared Light For EE-7500 EE-IP1

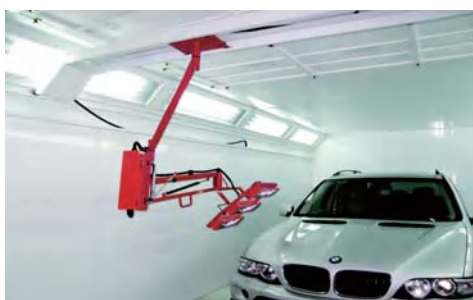

EE-IP2



EE-IP3



TECHNICAL DATA

Models	EE-IP1	EE-IP2	EE-IP3
Power supply	220V/50/1PH	220V/50/1PH	220V/50/1PH
Current	13.6A	9A	14A
Power	3x1000W	2x1000W	3x1000W
Temperature	60 °C -100 °C	60 °C -100 °C	60 °C -100 °C
heating area	900mmx1200mm	600mmx800mm	1000mmx1200mm
Baking distance	400-600mm	400-600mm	400-600mm
Primer	3-5min	3-5min	3-5min
The first pully	3-6min	4-7min	3-6min
The second pully	5-8min	6-9min	5-8min
Finish coat	10-15min	11-16min	10-15min
Varnish	10-15min	11-16min	10-15min
Adjust height of the lamp	250-2000mm	300-1900mm	150-2500mm
Packing size	1410x310x190mm+860x700x140mm	650x520x240mm	1760x1120x200mm
N.W.	26Kg	14Kg	50Kg
G.W.	30Kg	19Kg	65Kg

AUTO BODY REPAIR SERIES

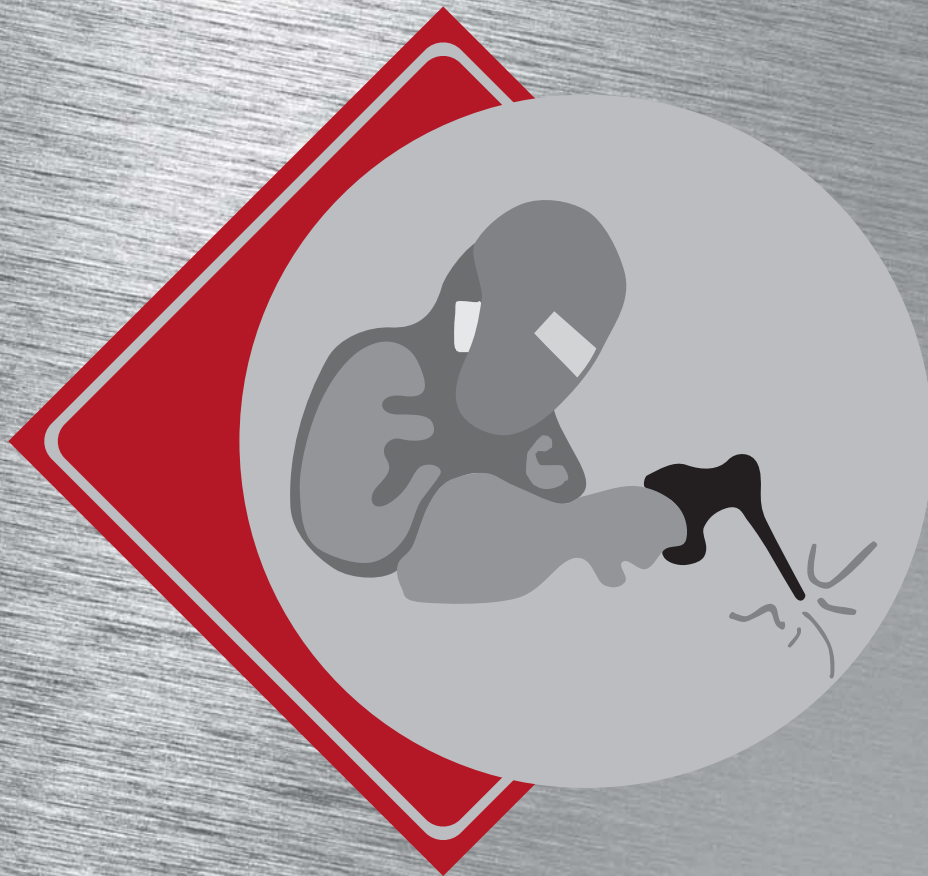

EE-CRT900B



EE-CRT3500

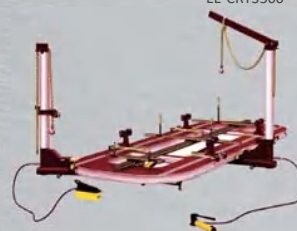

EE-SP5500



EE-SP6500



EE-MM2350



EE-MM2210



AUTO COLLISION REPAIR EQUIPMENT

EE-CRT900B



EE-CRT3500



MAIN FEATURES

EE-CRT900B

- Stronger and longer service life.
- Minimum height is 140mm, vehicle could move on bench without ramp
- Top quality hydraulic system, powerful and reliable
- Fast speed clamp fixing system convenient and efficient.
- Pneumatic self-lock protective system, safety and reliable.
- Flexible moving, convenient operation, ideal for servicing light cars.

EE-CRT3500

- High precision and compact frame
- 300mm minimum height
- Top quality hydraulic system, powerful and reliable
- Strong pulling tower with 10 tons pulling force

TECHNICAL DATA

Models	Max Lifting Capacity	Bench Length	Bench Width	Bench Height	Max Pulling Force Of Puling Tower	Required Air Supply	G.W.	Post Working Range
EE-CRT900B	2.5T	3230mm	880mm	140-1400mm	10T	6-8 BAR	1282kg	360
EE-CRT3500	3.5T	5180mm	2000mm	530mm	10T	6-8 BAR	2224kg	360

DETAIL DISPLAY



Air Pump



Extension Measure Ruler



Clamp For EE-CRT3500

OPTIONAL ACCESSORIES



Clamp For BMW



Clamp For BENZ



Rolling Jack EE-CRT3500

WELDING MACHINGE & SPOT WELDING MACHINE



For Thin Plate
EE-SP5500

For Medium Plate
EE-SP6500



For Medium Plate
EE-MM2350



For Thin Plate
EE-MM2210

TECHNICAL DATA

Models	EE-SP5500	EE-SP6500
Input power	10KVA	11KVA
Fusing current	25A	32A
No-load voltage	5-10.5V	5-12V
Welding current (gun)	200-3500A	200-4000A
Single side spot welding range	0.8+0.8MM	0.8+0.8MM
Cable length(gun and ground wire)	1.5+2M	1.5+2M
Input voltage	220V/50HZ/1PH	380V/50HZ/1PH
Power	7.5kw	12.5kw

Models	EE-MM2210	EE-MM2350
Power supply	220V/50HZ/1PH	380V/50HZ/3PH
Input power	5.7KVA	11.1KVA
No-load voltage	16-34V	16-42V
Welding current range	35-210A	35-350A
Duty cycle	25%	25%
Weilding wire spool dia.	15KG Ø 300	15KG Ø 300
Flux cored wire	0.8-1.0	0.8-1.2
Steel wire	0.8-1.0	0.8-1.2
Stainless steel wire	0.8	0.8-1.0
Aluminum wire	0.8	0.8-1.0
Insulation class	F	F
Protection degree	1P21S	1P21S
Package(L x W x H) mm	925x385x655	860x360x940
G.W.	71Kg	95Kg

SHOP EQUIPMENTS



EE-RBT03-4



EE-RBT03



EE-RBT04



EE-PW20G



EE-PWAW



EE-SB2220



EE-AC270F



EE-AC285T



EE-AC390F



EE-9350



EE-9370C



EE-TC07



EE-TC003



PNEUMATIC OIL COLLECTING & DRAINING MACHINE



**For Truck
EE-290T**



**Extract & Collecting
Visible
Measuring Cup
EE-290DMC**



**Extract & Collecting
EE-290DC**

TECHNICAL DATA

Models	EE-290T	EE-290DMC	EE-290DC
Tank capacity	72L	72L	72L
Cup capacity	10L	10L	/
Tray capacity	10L	10L	10L
Suction speed with oil at 70-80 °C	0.6-1.6L/min	0.6-1.6L/min	0.6-1.6L/min
The height of oil draining	1.65m	1.65m	1.65m
Automobile dawdle	200L/min	200L/min	200L/min
Operating pressure	8-10bar	8-10bar	8-10bar
Oil draining pressure	1bar	1bar	1bar
Suction hose	1.5m	1.5m	1.5m
Draining hose	1.5m	1.5m	1.5m

DETAIL DISPLAY



Diameter 420mm Tray



Metal Fittings



Solid Bearing Wheel



Height Adjustable
Oil Pipe

BRAKE TESTER

4 In 1 Compact Testline EE-RBT03-4



MAIN FEATURES

Used for test the following functions of a vehicle under 3.5 tons weight:

- Vehicle Sideslip Test
 - Vehicle Sideslip Volume
 - Vehicle Sideslip Direction
- Vehicle Suspension Test (& Wheel Load)
 - Vehicle Static Wheel Load
 - Car Suspension Absorption Rate
 - Absorption Rate Difference between L/R Wheels
 - Assist to Noise detection
- Vehicle Brake Test
 - Wheel Resistance Force
 - Vehicle Max Brake Force
 - Brake Inbalance rate
 - Parking Brake Force.

- Vehicle Sideslip Tester

- Sideslip plate & Protection frame integrative structure
- Sideslip plate locker with inner key
- No maintenance body design
- Galvanized plate surface for extra long service life
- High precision sensor to ensure the exactitude of result
- Upper and lower dual bearing system makes smooth movement
- Selection of synchronic or independent motion type for different regulation requirement
- Over-value alarm function
- Standard RS-232 connection port

- Vehicle Brake Tester

- Corundum binding roller set for high adhesion in both dry and wet condition
- High precision sensor ensures the exactitude of inspection result
- Using of reinforced steel, strengthen and durable structure body
- High performance motor and gearbox
- Electronic subordinate roller (sensor roller) and speed sensor
- Automatic start and anti-peel tyre program
- Roller driven sort-out program (Air-lifter model available)
- Standard RS-232 interface connection

- Vehicle Suspension Tester

- EUSAMA measurement standard
- Wheel load function integrated
- Protection program by >200kg excited vibration
- High precision sensor ensures the exactitude of inspection result
- Galvanized plate for extra long service life
- Result display with visual graph

3T Brake Tester EE-RBT03



4T Brake Tester EE-RBT04



BRAKE TESTER

DETAIL DISPLAY



Load Cell



Brake Rollers



Standard Pc Control Unit



Gearbox & Motor



Main Circuit Board



Suspension Test



Brake Test

PIT WORK DRAWING

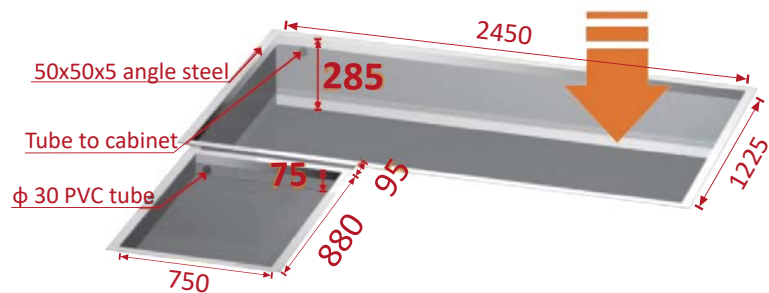
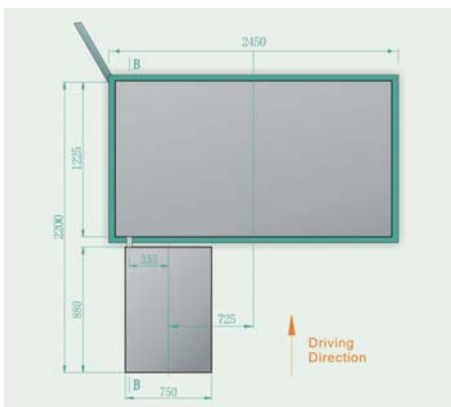

SCREW COMPRESSOR

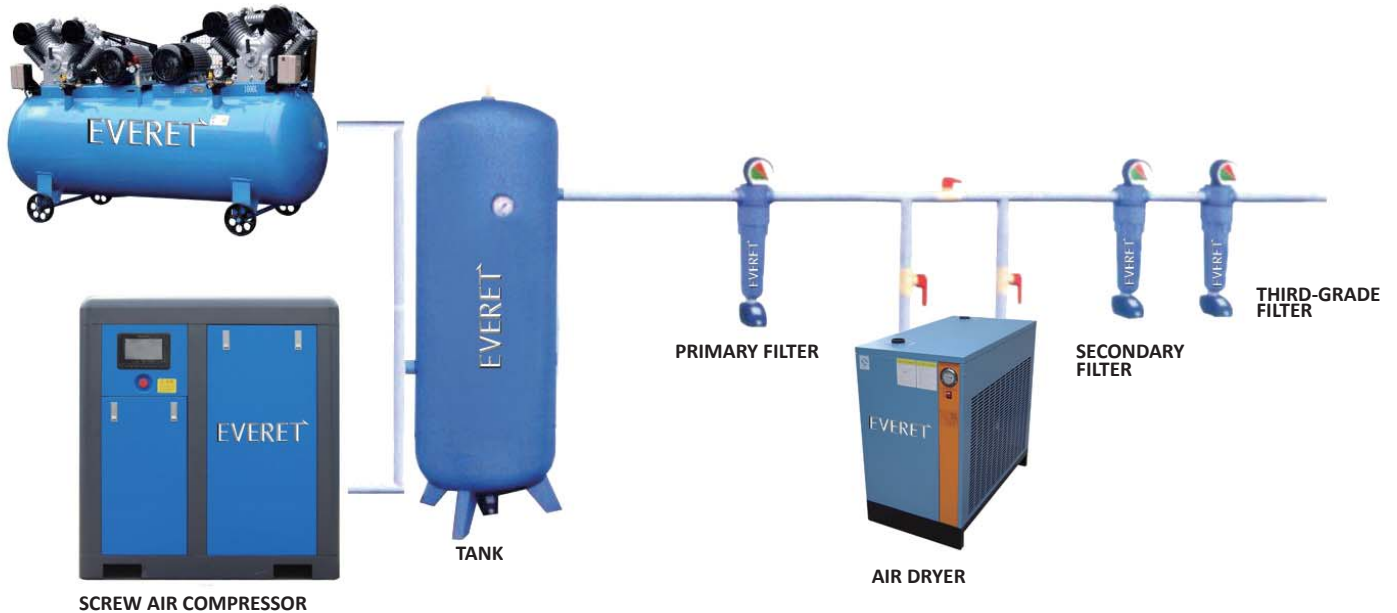

MAIN FEATURES

- Economical Operation Cost
- Excellent Adaptability to environment
- Imported advanced principal machine with high efficiency and reliability
- Superior electric control system

TECHNICAL DATA

Models	EE-AC1.1/8	EE-AC2.4/8	EE-AC3.4/8
Moter	7.5KW	15KW	22KW
Capacity(m3/min)	1.1	2.4	3.4
Work Pressor(Bar)	8	8	8
Air Dryer	EE-AC10A	EE-AC20A	EE-AC30A
Capacity(m3/min)	1.5	2.5	3.8
Rating pressure(BAR)	8	8	8

DETAILS DISPLAY

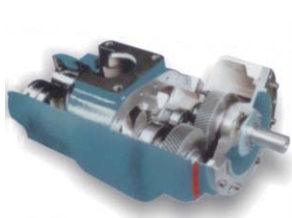

Well-known screw compressor end



Low consumption and high efficiency motor which is mewly special designed



Imported filtration system



Interactive control system



Imported air capacity control system



Imported advanced microcomputer controll which is powerful at troubles diagnosing and protection



Imported pressure controller and solenoid valve

AIR COMPRESSOR



EE-AC270F



EE-AC285T



EE-AC390F

TECHNICAL DATA

Models	EE-AC270F	EE-AC285T	EE-AC390F
Motor	2.2Kw/3HP	4Kw/5HP	7.5Kw/10HP
The cylinder (diameter X's amount)	70 × 2	85 × 1 95 × 1	90 × 3
Exhaust volume (L/min)	320	400	1100
Rating pressure (BAR)	8	12.5	8
Storage Volume (L)	100	135	225
G.W. (Kg)	112	190	275
Packing (mm) (L x W x H)	1140×480×880	1380×540×1100	1600×660×1230
Qty/20'	62	17	17
Voltage	220V/50HZ/1PH 380V/50HZ/3PH	380V/50HZ/3PH	380V/50HZ/3PH

BRAKE LATHE

EE-9350



**Gear Transmission
For Car**

EE-9370C



**Dc Motor
For Car & Light Truck**

TECHNICAL DATA

Models	EE-9350	EE-9370C
Spindle Travel (mm)	0-175	0-251
Spindle Speed (RPM)	70,88,118	70,88,118
Rotor Diameter (mm)	180-381	180-457
Rotor Thickness (mm)	48	102
Drum Diameter (mm)	152-711	152-711
Drum Depth (mm)	175	251
N.W.(Kg)	250	285

TOOL TROLLEY



EE-TC07

MAIN FEATURES

- Heavy duty steel structure ensures long lasting strength and durability.
- Four sides protection bars resist the impact and deformation.
- The cover board with 500KG load capacity, has the features of strong anti-embroadiered and good solvent resistance.
- Heavy duty casters made of TTE material.
- Very stable and reliable to use.
- Regular using tools can be placed orderly to improve the efficiency.

TECHNICAL DATA

Models	EE-TC07
Weight	54kg
Loading Capacity Of Drawer	45kg
Drawers	7 Drawers
Drawers Size	570x380x43mm x4, 570x380x100mmx1,
	570x380x120mmx2
Packing Size	765x510x885cm

EE-TC03

MAIN FEATURES

- Heavy-duty sivel casters (2-lockable).
- Electric static powder coating resists rust & scratches.
- Top cover & tool box keyed alike so one key opens both.

TECHNICAL DATA

Models	EE-TC03
LxWxH	920x500x420mm
G.W.	42Kg
N.W.	38Kg
QTY/20'	140units
QTY/40'	282units



PARTS WASHER & SAND BLASTER



EE-PW20G



**EE-PWAW
PNEUMATIC**



EE-SB1

MAIN FEATURES

EE-PW20G

- Rugged welded steel.
- Convenient removable work shelf.
- Parts basket for soaking small parts in solvent.
- Self-latching fuses linked fine cover.
- Electric requirement: 110V/60Hz(240V/50Hz) solvent pump.
- Max pump output through spigot: Recirculates 2.7-3.3 litre/min of solvent.
- Tank capacity: 20 Gallon.
- Solvent capacity: 12 Gallon.

EE-PWAW

- Cleaning tank capacity: 50 litre.
- Trolley tank capacity: 65 litre with level indicator.
- Compressor supply: 6-8 kg pressure.
- Pressure for output solvent: 0.4-0.5 kg.
- Flowing rate: 130kg/hour.
- Max working pressure: 125PSI..

EE-SB1

- Heavy steel construction double door on the side.
- Transparent glass viewing window.
- 40-80 PSI @ 15-25 CFM.
- Overall dimension: 138cm(H)x87cm(L)x63cm(W).
- Electrical requirements of light: 115V/230V.
- two lights.
- Maximum operation pressure:125 PSI.

TECHNICAL DATA

Models	EE-PW20G	EE-PWAW	EE-SB1
LxWxH	790x550x320mm	790x550x320mm, 730x460x440mm	960x620x625mm
G.W.	26 Kg	25/23 Kg	51 Kg
N.W.	23 Kg	23/21 Kg	48 Kg
Q'TY/20GP	210 units	93 units	63 units
Q'TY/40GP	420 units	200 units	129 units

OIL METER GUN

EE-OG25



EE-OG16



EE-OG15



MAIN FEATURES

- Suitable for dispensing kinds of motor oils, gear oils, automatic transmission oils, hydraulic fluids, anti-freeze liquids etc.
- Suitable for connecting 3:1 and 5:1 pump
- Four 3V battery, the battery life is 4 years
- Suitable for measuring the cubage of the liquid in the pipeline. Completed with oil outlet pipe, electronic oil meter gun oil gun etc. Equipped with rotating oil outlet pipe and anti-leaking connector. Measuring accurately. High repeated precision. simple operation. it can accumulate flow rate memory and it can preset oil flow.

DETAILS DISPLAY



TECHNICAL DATA

Models	EE-OG15	EE-OG16	EE-OG25
Inlet and outlet connections	1/2" BSP	1/2" BSP	1/2" BSP
Flow rate range	0-18L/min	0-18L/min	0-18L/min
Operating pressure	0.5bar-50bar	0.5bar-50bar	0.5bar-50bar
Oil temperature range	max.60 °C	max.60 °C	max.60 °C
Applied Viscosity of fluid	10-5000Mpas	10-5000Mpas	10-5000Mpas
Accuracy	±3‰	±3‰	±3‰
Accurate Unit	0.0L	0.0L	0.0L
Preset Oil Flow	•	○	○
Accumulate flow rate memory	•	•	○
Manual filling	○	○	•

WALL MOUNTED OIL DISPENSING PUMP



EE-OK675



EE-OK680

MAIN FEATURES

- Digital metering refueling gun, can display the single and cumulative amount of fuel gas, When the amount of oil to reach the required amount of oil, automatically shut down.measurement accuracy is $\pm 3\%$;
- The cart can carry 50-208KG barrel filled with Engine oil mobile refueling, convenient and quick
- Equipped with 2 Universal wheels and 2 widened double bearing fixed wheels
- The cart designed with various hooks, gun free, hanging on the hook body, make the maintenance environment clean and orderly.

DETAILS DISPLAY



TECHNICAL DATA

	EE-OK680	EE-OK675
Compression Ratio	5:1	5:1
Air inlet connection	1/4"	1/4"
Oil outlet connection	1/2"	1/2"
Oil capacity at 6 bar(free output)	18L/min	18L/min
Operating pressure	6-8 bar	6-8 bar
Suction tube diameter	42mm	42mm
Air consumption	270L/min	270L/min
Noise level	81 bar	81 bar
Max viscosity of the delivered oil	240SAE	240SAE
Oil hose reel	•	•
Length of the oil tube	10m	10m
Gun	Electronic oil meter gun	Electronic oil meter gun
Gun accuracy	$\pm 3\%$	$\pm 3\%$
Oil gun nozzle	automatic	automatic
Length of the suction tube	940mm	270mm
GW/NW.	42KG/39KG	42KG/39KG
Package size	550X600X280+1315X300X150mm	550X600X280+1315X300X150mm

OIL DISPENSING TROLLEY KITS

EE-OK100



EE-OK150



MAIN FEATURES

- Digital metering refueling gun, can display the single and cumulative amount of fuel gas, When the amount of oil to reach the required amount of oil, automatically shut down.measurement accuracy is $\pm 3\%$.
- The cart can carry 50-208KG barrel filled with engine oil mobile refueling, convenient and quick.
- Equipped with 2 Universal wheels and 2 widened double bearing fixed wheels.
- The cart designed with various hooks, gun free, hanging on the hook body, make the maintenance environment clean and orderly.

TECHNICAL DATA

Models	EE-OK100	EE-OK150
Compression Ratio	5:1	5:1
Air inlet connection	1/4"	1/4"
Oil outlet connection	1/2"	1/2"
Oil capacity at 6 bar(free output)	18L/min	18L/min
Operating pressure	6-8 bar	6-8 bar
Suction tube diameter	42mm	42mm
Air consumption	270L/min	270L/min
Max viscosity of the delivered oil	240SAE	240SAE
Oil hose reel	•	o
Length of the oil tube	10m	4m
Gun	Electronic oil meter gun	Electronic oil meter gun
Gun accuracy	$\pm 3\%$	$\pm 3\%$
Oil gun nozzle	automatic	automatic
Length of the suction tube	940mm	940mm
GW/NW.	77KG/62KG	40KG/37KG
Package size	860X860X120mm+300X160X1315mm+550X600X280mm	880X870X180mm+300X160X1315mm

HOSE REEL



EE-HR210L



EE-HR110E



EE-HR210AL



EE-HR310ALE



EE-HR010A



EE-HR310W



EE-HR410C

MAIN FEATURES

- The central axis and other rotating parts are all made of brass, which ensure its friction resistance, good handling for stretch out and draw back
- The side plate is made of alloy steel, and is solid, durable and no deformation
- The quick coupling is made of brass, and is strong, durable, easy to connect and with long service life. And it's applicable to all kinds of standard connector
- The shell is made of high quality engineering plastic with module production, which ensure its beautiful appearance, impact can be ensured, aging resistance and long service life
- The hose material is made of advanced polyether so that ensure its good water resistance, aging resistance and long service life

HOSE REEL

TECHNICAL DATA

Models	EE-HR110E	EE-HR210L	EE-HR010A	EE-HR310W	EE-HR410C	EE-HR210AL	EE-HR310ALE
Function	Electric line	Light line	Air line	Water line	Destergent line	/	/
Diameter cord	1.5mm	1.5mm	/	/	/	/	/
Output wire length	10m	10mm	/	/	/	/	/
Power Voltage	210KW/240V	210KW/240V	/	/	/	/	/
Socket	3x3	3x3	/	/	/	/	/
LED Light Power	/	3W	/	/	/	/	/
GW/NW	5.5kgs/4.5kgs	6kgs/5kgs	6kgs/5kgs	6kgs/5kgs	6kgs/5kgs	26kgs/24kgs	30.5kgs/28.5kgs
Package Size(mm)	385X330X210	385X330X210	385X330X210	385X330X210	385X330X210	730X560X495	730X560X495
Air outlet pipe length(m)	/	/	10m	10m	10m	/	/
Specs of the pipe	/	/	ϕ6.5X10	ϕ8X12	ϕ8X12	/	/
Working pressure(Bar)	/	/	18	18	18	/	/
Matenal of double-layer pipe	/	/	PU Grippers	PU Grippers	Polyether	/	/
Light Air hose reel	/	/	/	/	/	10m	10m
Light Electric line hose reel	/	/	/	/	/	10m	10m
Light light line hose reel	/	/	/	/	/	/	10m
Filberglass housing size	/	/	/	/	/	728X528X400mm	728X528X400mm

DETAILS DISPLAY



AC REFRIGERANT RECOVER MACHINE



EE-AC540



EE-AC565



EE-AC530

MAIN FEATURES

- Recover and purify refrigerant into cylinder.
- Vacuumize the air conditioner
- Charge refrigerant into air conditioner from cylinder
- Charge the compressor oil into air conditioner
- Drain waste oil that is separated from refrigerant automatically
- Wheel brake and wheel cover
- Big gauge/gauge cover
- Automatic operation prompt, user no need operation training

TECHNICAL DATA

Models	EE-AC540	EE-AC565	EE-AC530
Refrigerant type	R134a	R134a	R134a
Power	800W	750W	750W
Recovery Speed	EE-OK 400g/min	300g/min	EE-OK675 300g/min
Charge Speed	1000g/min	800g/min	800g/min
Vacuum Speed	10.8m ³ /h	5.4m ³ /h	5.4m ³ /h
Cylinder capacity (KG)	15	10	10
LCD type	Big Colorful LCD	Colorful LCD	Colorful LCD
Recovery, Vacuum, Refilling	•	•	•
A/C flushing	•	•	○
Leakage hunting, and oil draining	•	○	○
Database for popular automobiles	•	○	○
Fan and condensor	•	•	•
Built-in Printer	•	○	○
Packing Size (LXWXH)mm	710X860X1470	640X670X1300	690X760X1350
GW./NW.(KG)	132/115	88/75	108/90

AUTOMATIC TRANSMISSION



MAIN FEATURES

- Equal oil pressure and volume replacement
- Oil flow adjustment free
- Full automatic operation, high efficiency, reliable quality
- The unique pairs of oil passages are designed
- The amount of oil change can be 100%
- Special-purpose adapters uses in Europe, America, etc.

DETAILS DISPLAY



Oil pressure gauge

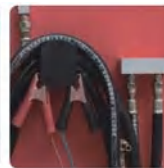

Input & output oil pipe

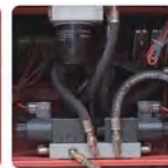

Magnetic valve & filter



Safety tube

EE-OC800XA

TECHNICAL DATA

Models	EE-OC800XA
Voltage: DC12V	DC12V
Maximum power: 250W	250W
Pressure gauge: 0 ~ 150psi	0 ~ 150psi
Length of oil outing pipe: 2.5m	2.5m
Length of oil return pipe: 2.5m	2.5m
Length of oil exhaust pipe: 1m	1m
Filter accuracy: 5um	5um
Fuel tank: 20L x 2	20L x 2
Equivalent replacement error: ± 100 g	± 100 g
Noise: <70db	<70db

BRAKE OIL

EE-BOC500R

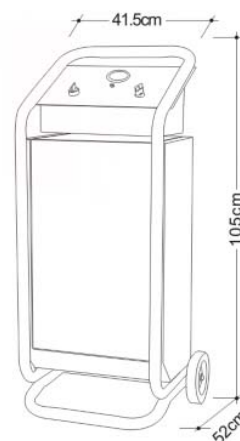
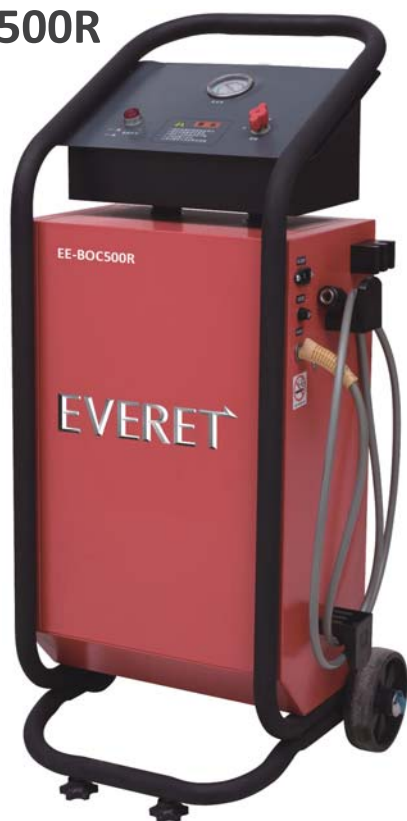

MAIN FEATURES

- Adopted below zero pressure suck oil operation program, which is safe, high efficiency changes brake oil 100% brake oil completely and return to original brake function, changes. Only needs one person operate, convenient and swifter

TECHNICAL DATA

Models	EE-OC800XA
Power	0.18kw
Voltage	AC 220V 50HZ or DC 12V
Vacuum degree	0-minus 0.08Mpa

DETAILS DISPLAY

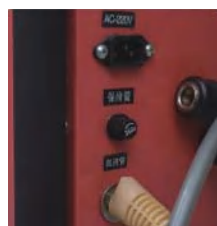

POWER STEERING MACHINE



EE-PSM1000

MAIN FEATURES

- Adopted the safest pneumatic pump and electric pump to adjust system by identical rate of flow pressure. It works on the equal pressure and electric current. Suction and drainage proceed at the same time. Whole the procedures are simple and safe. In order to maintain completely, we access independent cyclic cleaning system, to clean greasy filter and dirt from oil pipe thorough.

TECHNICAL DATA

Models	EE-PSM1000
Voltage	DC 12V or AC220V 50HZ
Power	0.36KW

DETAILS DISPLAY



Oil pressure gauge

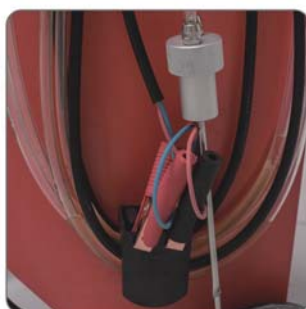

Return/inlet liquid pipe



Inlet new oil

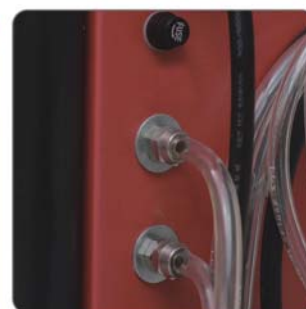

Pipe

AIR OPERATED GREASE PUMP



EE-290GP

MAIN FEATURES

- Pneumatic drive, safe and reliable.
- Barrel body welding smooth, exquisite workmanship.
- 50: 1 pneumatic pump, high oil output.
- Configuration of the oil Tsui, Tsim Tsui, for a variety of conditions.

TECHNICAL DATA

Models	EE-290GP
Tank Capacity	13kgs
Compression ratio	50:1
Air Inlet Connection	G1/4"
Grease Outlet Connection	G3/8"
Relative Capacity(free delivery at 6 bar)	500g/min
Working Pressure Bar	5-6 bar
Suction Diameter	32mm
Suction Length	500mm
GW/NW.	17.5KG/16KG
Package size	340X380X890mm

DETAILS DISPLAY



SHOP TOOLS SERIES



EE-BJL2



EE-BJL3



EE-BJS2



EE-BJS3



EE-SP010



EE-SPO20AP



EE-SP030



EE-SC011



EE-SC001



EE-SC002



EE-FJ021-7S



EE-ARJ02



EE-FJ025-28



EE-FL2000-2



EE-JS021



EE-BOJ02



EE-TJ806



EE-TJ901



EE-TJ702



BALLOON JACK

2T
EE-BJL2

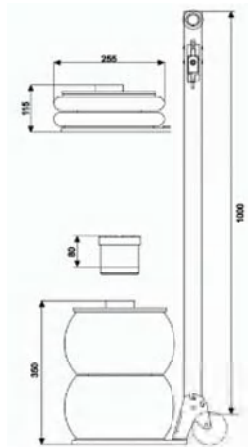

2T
EE-BJL3

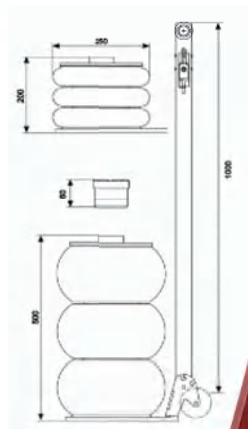

2T
EE-BJS2



2T
EE-BJS3

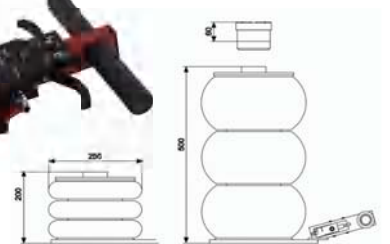

TECHNICAL DATA

	EE-BJS2	EE-BJL2	EE-BJS3	EE-BJL3
Capacity	2T	2T	2T	2T
Air Pressure	0.7-1.0Mpa	0.7-1.0Mpa	0.7-1.0Mpa	0.7-1.0Mpa
Min Height	115mm	115mm	200mm	200mm
Lifting height	350mm	350mm	500mm	500mm
Max Height	430mm	430mm	560mm	560mm
Extension	80mm	80mm	60mm	60mm

ENGINE CRANE & SHOP PRESS



10T
EE-SP010



20T
EE-SP020AP



30T
EE-SP030

TECHNICAL DATA

Models	Capacity (ton)	Max. Working Distance (mm)	Stroke (mm)	G.W. (kg)	N.W. (kg)	Package Size (cm) (LxWxH)	QTY/20'CY (pcs)
EE-SP010	10	858	135	72	70	132x25x25	250
EE-SP020AP	20	1035	145	35/57	34/56	160x22x12, 66x24x26	210
EE-SP030	30	820	150	160	150	164x37x28	120

Models	Capacity (ton)	Max. height (mm)	G.W. (Kg)	N.W. (Kg)	Package Size (cm) (LxWxH)	QTY/20'CY (pcs)
EE-SC011	1T	2150	79	74	139x27x17, 65x57x9	165
EE-SC001	2T	2170	83	80	143x27x17, 85x57x9	148
EE-SC002	3T	2100	133	130	133x83x11, 143x30x21	140



1T
EE-SC011



2T
EE-SC001



3T
EE-SC002

FLOOR JACK



2T
EE-FJ021-7S



3T
EE-FJ031-34



2T
EE-ARJ02

TECHNICAL DATA

Models	Capacity (ton)	Height (mm)		G.W. (Kg)	N.W. (Kg)	Package size(cm) (LxWxH)	Qty/20'CY (pcs)
		Max	Min				
EE-FJ021-7S	2	360	88	15.9	14	59x28x18	450
EE-FJ025-28	2.5	460	85	36	33.5	69x38x21	420
EE-FJ031-34	3	475	145	37	35	73x37x21	400
EE-ARJ02	2	420	95	21	19.8	72x33x20	561
EE-FL2000-2	2	800	140	63	58	126x44x21	230
EE-FJ2000-3	3	630	145	69	65	118x47x21	230
EE-FJ2000-5	5	565	160	118	93	157x42x29	160

2.5T
EE-FJ025-28



2T
EE-FJ2000-2



3T
EE-FJ2000-3



LOW PROFILE DESIGN

5T
EE-FJ2000-5



BOTTLE JACK & JACK STAND



2T
EE-BOJ02



3T
EE-BOJ03



5T
EE-BOJ05



8T
EE-BOJ08

TECHNICAL DATA

Models	Capacity (ton)	Height (mm)		G.W. (Kg)	N.W. (Kg)	Package Size (cm) (LxWxH)	QTY/20'CY (pcs)
		Max	Min				
EE-BOJ02	2	345	180	2.8	2.5	14x11x20	7000
EE-BOJ03	3	364	191	3.2	2.9	14x11x21	6000
EE-BOJ05	5	388	200	4.0	3.8	15x12x22	4400
EE-BOJ08	8	392	200	5.7	5.5	17x12x22	3000
EE-JS021	2	425	270	5.5	5	19x19x34	2400
EE-JS031	3	450	305	7.2	6.6	24x21x26	450
EE-JS061	6	620	400	14	13.2	31x28x47	425
EE-JS121	12	760	500	27	26.5	30x33x58	440



2T
EE-JS021



3T
EE-JS031



6T
EE-JS061



12T
EE-JS121

TRANSMISSION JACK



0.5T
EE-TJ701

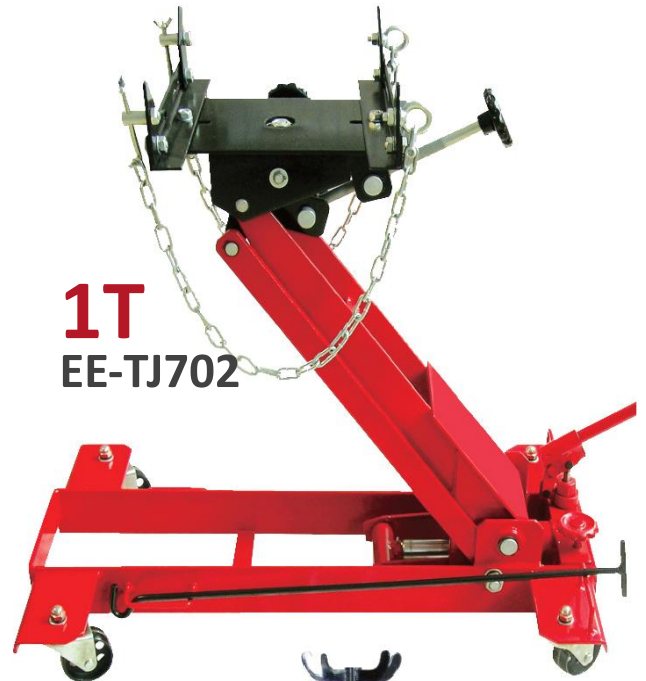

1T
EE-TJ702



1T
EE-TJ806



0.5T
EE-TJ801



0.5T
EE-TJ901

MAIN FEATURES

- Wide leg base with swivel wheels (brakes on wheels)
- Fully Adjustable Universal Saddle
- Foot operated hydraulic pump for ease of control when positioning or removing transmission

TECHNICAL DATA

Models	Capacity (ton)	Height (mm)		G.W. (kg)	N.W. (kg)	Package Size (cm) (LxWxH)	QTY/20'CY (pcs)
		Max	Min				
EE-TJ702	1	775	210	72	67	96x55x35	250
EE-TJ701	0.5	755	190	63	58	96x55x35	320
EE-TJ901	0.5	1900	1100	40	32	112x34x30	258
EE-TJ801	0.5	1820	895	85	75	95x58x20	219
EE-TJ806	1	1800	830	90	77	560x370x910	150

HYDRAULIC VEHICLE POSITIONING JACK

EE-WD8014



EE-WD8016



TECHNICAL DATA

	EE-WD8014	EE-WD8016
	PVC roller + NYLON wheels	Aluminum roller +PU wheels
Capacity	1500lbs	1500lbs
Roller length	12"	12"
Min/Max width between rollers	345-620mm	345-620mm
Package	680x620x220mm	680x620x220mm
N.W./G.W.	20.5KG/22.5KG	18.5KG/20.5KG

OPTIONAL

